

SNADI[®]

User Manual

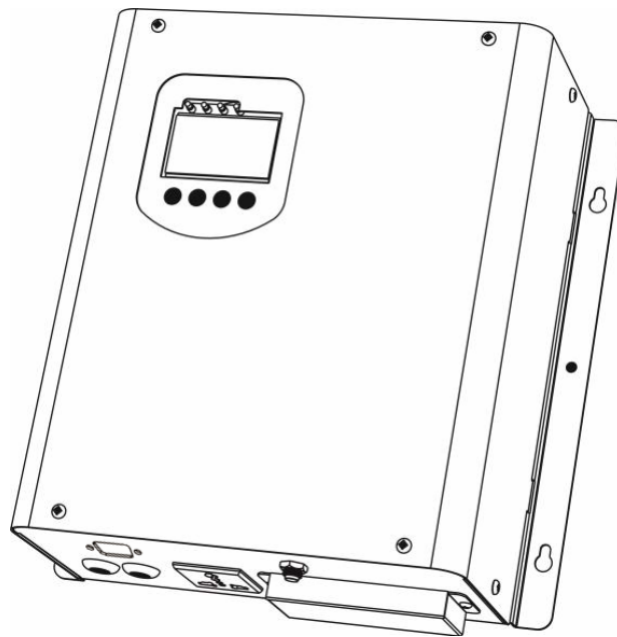

NKM series 1000E

Dear Customers

It's very grateful to you for trusting our company and selecting our products! Before using this product, please read carefully this user manual, including installation, using, failure investigation and other important information and suggestion, we also suggest you keep this manual well!

Catalogue

1、 Product Features -----	01
2、 Installation and storage Guide -----	02
3、 Equipment appearance graphical representation guide -----	03
4、 Operating instructions-----	04
5、 Equipment wiring diagram guide -----	17
6、 Care and Maintenance -----	19
7、 Error code and solution -----	20
8、 Judgment and treatment for simple faults -----	21
9、 Technology parameter sheet -----	22

1 Product Features

- Excellent performance because of double MCU intelligent control technology.
- Settable mains supply preferred mode and battery preferred mode for flexible using.
- Settable charge current and multiple threshold voltages for meeting the selection of the different types of batteries.
- Settable output voltage and frequency, making it convenient and practicable.
- Settable unattended function, good for wide range of application scenarios.
- Pure sine wave output, suitable for various types of loads .
- Intelligent cooling device, efficient and energy-saving.
- LCD real-time display of equipment information and operating status.
- Overall protection and alarm functions, safe and reliable.

2 Installation、 Storage instruction

(1) Unpacking Inspection

1.1 Open the package, inspect product accessories, including:1 host,1 piece user manual

1.2 Inspect whether the machine have been damaged during the transport or not, If it have some damage, don't start the machine, contact the logistics company and dealer.

(2) Installation、 Storage Notes

2.1 The product installation should be operated by professionals, or assisted by dealer.

2.2 If it needs to transport machine, please take proper protection measures; move the machine from low temperature environment to high temperature environment, may appear droplet, please keep it dry and ensure safety.

2.3 Don't let the machine exposure in damp, inflammable and explosive or large accumulation of dust environment. Don't cover and block vents, please preset above 10cm air circulation clearance so that having a good cooling.

2.4 It is battery switch must be shut down when the equipment is not connected with the grid and not being used

3 Equipment appearance graphical representation guide

(1) Front panel diagram introduction

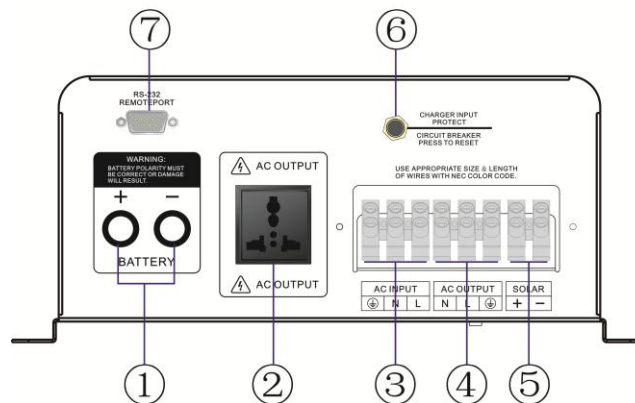

Introduction:

- ①-- Battery input
- ②-- AC output port
- ③-- AC input port
- ④-- AC output port
- ⑤-- Solar input port
- ⑥-- AC input fuse holder
- ⑦-- RS232





4 Operating instructions

4.1 Panel LCD display graphical representation instruction

The LCD is on the front panel of the inverter and consists of four buttons and an LCD screen, displaying the working status and information of the inverter.









4.1.1 Description of buttons











Button Function		Instruction
	ON/OFF	On/off button single control
	UP	Short press to view inverter parameters in the main interface, short press to increment in the setting interface.
	Down	Short press to view the inverter parameters in the main interface, and short press to reduce in the setting interface.
	Funct	Under the main interface, press and hold for less than 5 seconds to enter the setting interface, under the setting interface, press and hold to confirm the parameters.



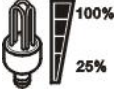

4.1.2 LED Status Description

LED display			Description
PV	Green	Light	PV start charging
		OFF	PV stop charging
LINE	Green	Light	The AC is connected and the output is bypassed
		OFF	Do not connect AC power or it is in inversion state
		Flash	AC power is connected and the device's output is in off state.
INV	Yellow	Light	The device is in inversion state
		OFF	The device is not in inversion state
FAU	Red	Light	AC output overload or Inverter fault
		OFF	The device work normally

4.1.3 LCD Display Icon Description

Icon	Function description
parameters information	
	Indicates the AC input
	Indicates the PV input
	AC input voltage, PV input voltage
	Indicates the setting programs.
	Working mode
	AC Output Voltage, Battery Voltage, AC Load Capacity, AC Output Frequency, PV Charge Current, PV Charge Power, PV Total Power Generation.

Battery icon instruction				
LCD display	Status	Battery voltage values/12V; *A (pcs)		
	Twinkle	< 10.5V;*A		
	Lighten	10.5~11.2V;*A		
	Lighten	11.2~11.6V;*A		
	Lighten	11.6~12.1V;*A		
	Lighten	12.1~12.5V;*A		
	Lighten	> 12.5V;*A		
Load icon instruction				
LCD display	Function instruction			
	0%~24%	25%~49%	50%~74%	75%~100%
				
	Output overload reminder			

Working mode Icon instruction		
LCD display	Function instruction	
	Grid input icon	
	AC-DC icon	
	DC-AC icon	
Buzzing icon instruction		
	Lighten	Prohibit buzzer tweet
	dark	Start buzzer tweet
Fault/abnormal icon instruction		
	Fault/Abnormal reminder	

4.1.4 LCD display main interface and instructions

View the LCD main interface by pressing the "Up" or "Down" key to switch in turn, the information includes: working mode, AC input/output voltage, battery voltage, output frequency, load capacity, etc.;

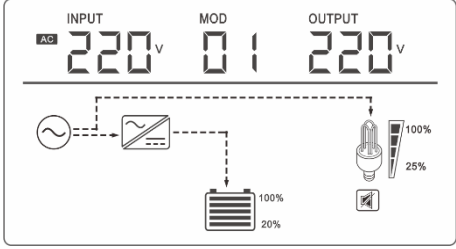
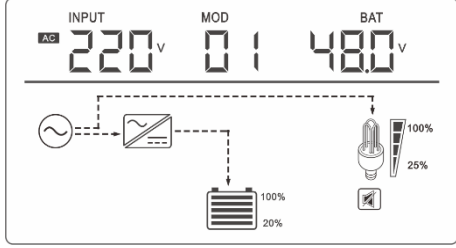
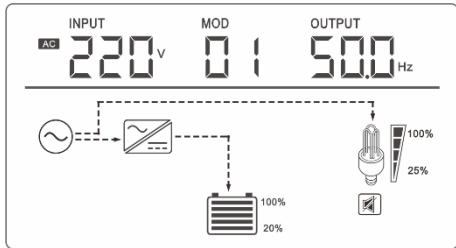
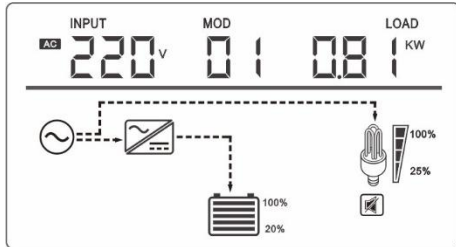
Selectable information	LCD display
Input voltage / Output voltage (Default interface)	<p>Input voltage=220V, Output voltage=220V</p>  <p>The LCD display shows 'INPUT 220v', 'MOD 01', and 'OUTPUT 220v'. Below the display are icons for AC input, a battery with 100% and 20% levels, and an output load with 100% and 25% levels.</p>
Input voltage / Battery voltage	<p>Input voltage = 220V, Battery voltage=48.0V</p>  <p>The LCD display shows 'INPUT 220v', 'MOD 01', and 'BAT 48.0v'. Below the display are icons for AC input, a battery with 100% and 20% levels, and an output load with 100% and 25% levels.</p>
Input Voltage / Output Frequency	<p>Input Voltage=220V, Output Frequency=50Hz</p>  <p>The LCD display shows 'INPUT 220v', 'MOD 01', and 'OUTPUT 50.0Hz'. Below the display are icons for AC input, a battery with 100% and 20% levels, and an output load with 100% and 25% levels.</p>
Input voltage / load power	<p>Input voltage =220V, load power=0.81KW.</p>  <p>The LCD display shows 'INPUT 220v', 'MOD 01', and 'LOAD 0.81KW'. Below the display are icons for AC input, a battery with 100% and 20% levels, and an output load with 100% and 25% levels.</p>

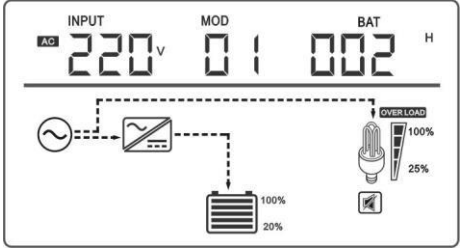
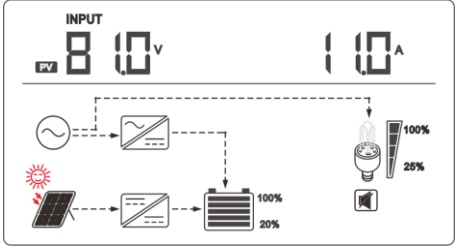
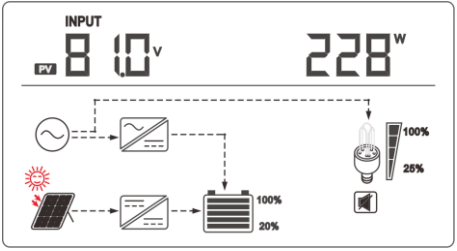
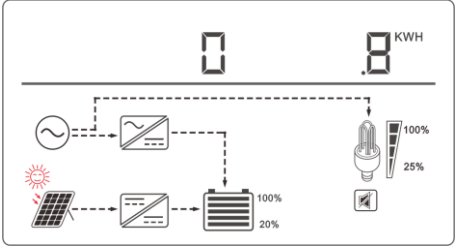
<p>Input voltage /Display of the remaining power time of the lithium battery (this interface will be displayed only when the lithium battery protocol is selected and communication is established)</p>	<p>Input voltage =220V, Display of the remaining power time of the lithium battery=2H.</p> 
<p>PV Input voltage/ PV Charge Current</p>	<p>PV Input voltage =81.0V, PV Charging current=11.0A</p> 
<p>PV Input voltage/ PV Charge Power</p>	<p>PV Input voltage =81.0V, PV Charge Power =228W</p> 
<p>PV Total Power Generation</p>	<p>PV Total Power Generation =0.8KWH</p> 

4.1.5 LCD parameter setting

Press and hold the "Funct" button for more than 5 seconds in any main interface to enter the program setting mode, and the program option is flashing. Short press the "Up" or "Down" button to select the program, and then short press the "Funct" button to enter, the corresponding parameters It is flashing. Short press the "Up" or "Down" key to set the parameter value, short press the "Funct" key again to confirm and return to the program setting mode.

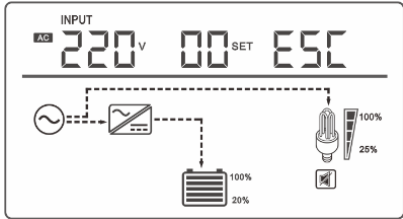
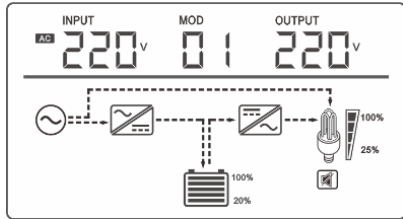
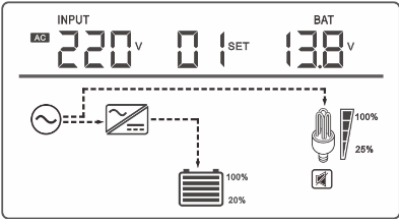
program option	Description	Options can be set			
00	Exit setting	Short press the "Funct" key when "00" is flashing, "00" is always on, short press the "Funct" key again to exit the program setting mode and return to the main interface.			
		<p>00-Exit program option</p> 	<p>main interface</p> 		
01	Charging voltage Setting (After setting restart to take effect)	For devices with a rated voltage of 12VDC, the default: 13.8V. The setting range is: 12-15V, and the variable of each short press is 0.1V. All specifications and configurations are shown in the table below:			
		Rated voltage	default	range	Variable for each short press
		12V	13.8V	12.0-15.0V	0.1V
		24V	27.6V	24.0-30.0V	0.2V
		48V	55.2V	48.0-60.0V	0.4V
		96V	110.4V	96.0-120.0V	0.8V
					

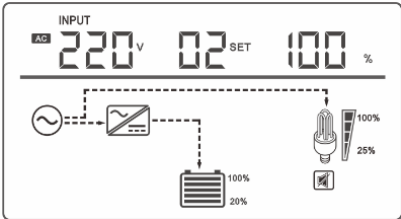
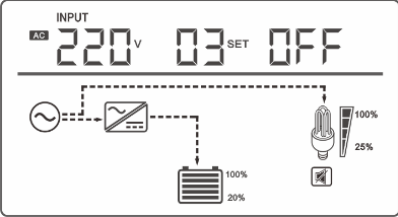
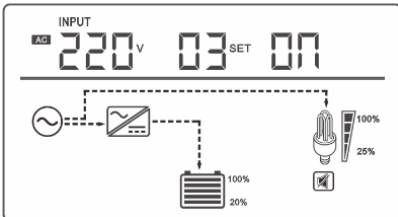
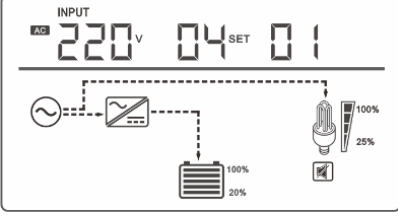
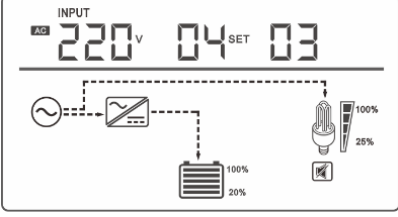
02	<p>Set the percentage of mains charging current</p> <p>(After setting effective immediately)</p>	<p>01 mode default: 100%, 03 mode default: 0%. The setting range is: 0%-100%, and the variable of each short press is 10%.</p> 
03	<p>Buzzer beep mode setting</p> <p>(After setting effective immediately)</p>	<p>Default:OFF, the buzzer is prohibited from beeping. The setting mode is: OFF or ON.</p> <div style="display: flex; justify-content: space-around;"> <div data-bbox="571 607 978 882"> <p style="text-align: center;">OFF</p>  </div> <div data-bbox="1050 607 1457 882"> <p style="text-align: center;">ON</p>  </div> </div>
04	<p>Working mode setting</p> <p>(After setting effective immediately)</p>	<p>Default: 01, mains priority mode. Setting mode: 01 or 03.</p> <div style="display: flex; justify-content: space-around;"> <div data-bbox="571 976 978 1252"> <p style="text-align: center;">01</p>  </div> <div data-bbox="1050 976 1457 1252"> <p style="text-align: center;">03</p>  </div> </div> <p>01 Mains power priority mode: Input the mains power, the device provides power to the load through the bypass, and at the same time replenishes the battery pack; when the mains power is too high/low/seriously distorted and other abnormal conditions, the device converts the energy of the battery pack into High-quality power is provided to the load. (Set 01 mode, the percentage of mains charging current is 100% by default)</p> <p>03 Battery priority mode: The first time the device is started to operate in the mains priority mode, the mains supplies power to the load but does not replenish power to the battery pack (charging function can be set), when the battery pack is charged to the battery priority start voltage value by other energy sources, the load The energy of the battery pack is converted into high-quality power to provide power; as the voltage of the battery pack drops to the priority termination voltage value of the battery, the device provides power to the load through the mains bypass. (Set 03 mode, the charging current of the mains The percentage is 0% by default)</p>

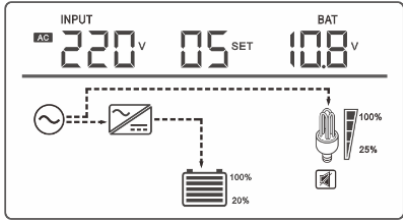
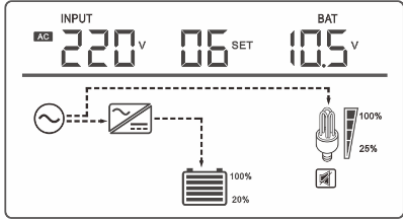
05	<p>Battery low voltage alarm setting</p> <p>(After setting effective immediately)</p>	<p>For devices with a rated voltage of 12VDC, the default: 10.8V. The setting range is: 9.5-12.5V, and the variable of each short press is 0.1V. All specifications and configurations are shown in the table below:</p>			
		Rated voltage	default	range	Variable for each short press
		12V	10.8V	9.5-12.5V	0.1V
		24V	21.6V	19.0-25.0V	0.2V
		48V	43.2V	38.0-50.0V	0.4V
		96V	86.4V	76.0-100.0V	0.8V
					
06	<p>Battery low voltage protection setting</p> <p>(After setting effective immediately)</p>	<p>For devices with a rated voltage of 12VDC, the default: 10.5V. The setting range is: 9.0-12.0V, and the variable of each short press is 0.1V. All specifications and configurations are shown in the table below:</p>			
		Rated voltage	default	range	Variable for each short press
		12V	10.5V	9.0-12.0V	0.1V
		24V	21.0V	18.0-24.0V	0.2V
		48V	42.0V	36.0-48.0V	0.4V
		96V	84.0V	72.0-96.0V	0.8V
					

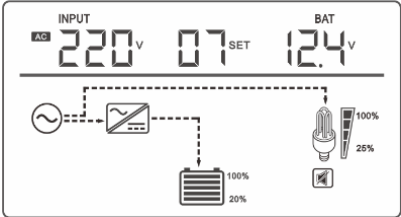
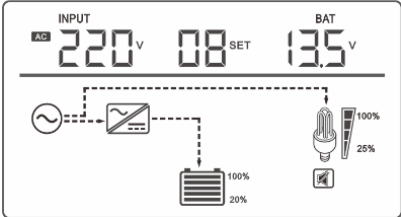
07	<p>Battery 100% voltage setting (for battery display) (After setting effective immediately)</p>	<p>For devices with a rated voltage of 12VDC, the default: 12.4V. The setting range is: 11.0-14.0V, and the variable of each short press is 0.1V. All specifications and configurations are shown in the table below:</p>			
		Rated voltage	default	range	Variable for each short press
		12V	12.4V	11.0-14.0V	0.1V
		24V	24.8V	22.0-28.0V	0.2V
		48V	49.6V	44.0-56.0V	0.4V
		96V	89.2V	88.0-112.0V	0.8V
					
08	<p>Battery priority start voltage setting (After setting effective immediately)</p>	<p>For devices with a rated voltage of 12VDC, the default: 13.5V. The setting range is: 11.5-14.5V, and the variable of each short press is 0.1V. All specifications and configurations are shown in the table below:</p>			
		Rated voltage	default	range	Variable for each short press
		12V	13.5V	11.5-14.5V	0.1V
		24V	27.0V	23.0-29.0V	0.2V
		48V	54.0V	46.0-58.0V	0.4V
		96V	108.0V	92.0-116.0V	0.8V
					

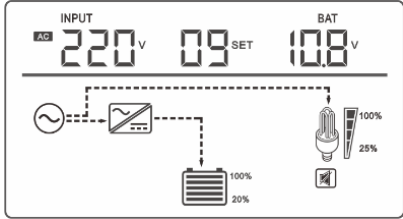
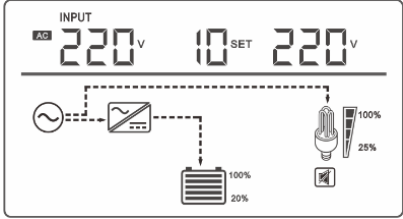
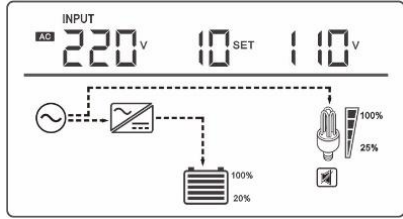
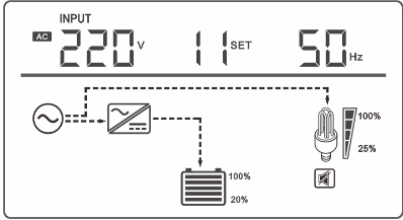
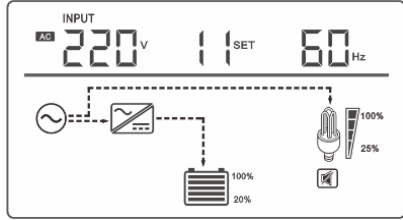
09	<p>Battery priority termination voltage setting</p> <p>(After setting effective immediately)</p>	<p>For devices with a rated voltage of 12VDC, the default: 10.8V. The setting range is: 9.5-12.5V, and the variable of each short press is 0.1V. All specifications and configurations are shown in the table below:</p>			
		Rated voltage	default	range	Variable for each short press
		12V	10.8V	9.5-12.5V	0.1V
		24V	21.6V	19.0-25.0V	0.2V
		48V	43.2V	38.0-50.0V	0.4V
		96V	86.4V	76.0-100.0V	0.8V
					
10	<p>Inverter output voltage setting</p> <p>(After setting restart to take effect)</p>	<p>Default: 220V. The setting range is: 200V-240V. Default: 110V. The setting range is: 100V-120V.</p>			
		220V		110V	
					
11	<p>Inverter output frequency setting</p> <p>(After setting effective immediately)</p>	<p>Default: 50Hz. Setting mode: 50Hz or 60Hz.</p>			
		50Hz		60Hz	
					

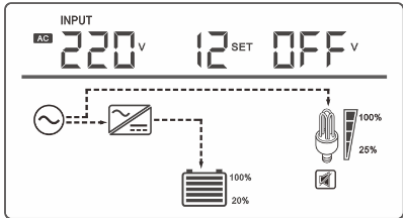
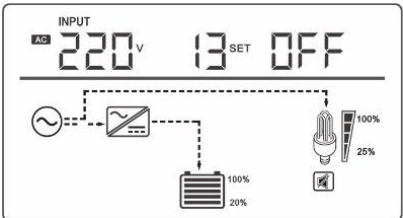
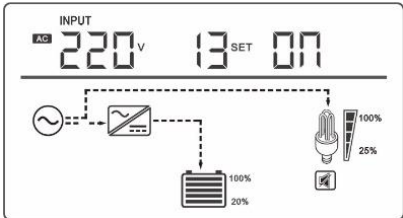
12	Unattended function setting (After setting effective immediately)	For devices with a rated voltage of 12VDC, the default: OFF. The setting range is: 11.0-14.5V, and the variable of each short press is 0.1V. All specifications and configurations are shown in the table below:			
		Rated voltage	default	range	Variable for each short press
		12V	OFF	11.0-14.5V	0.1V
		24V		22.0-29.0V	0.2V
		48V		44.0-58.0V	0.4V
96V	88.0-116.0V	0.8V			
					
13	AC output mode setting option (After setting restart to take effect)	Default: OFF. Don't turn on AC output. Setting mode: OFF or ON.			
		<p style="text-align: center;">OFF</p> 		<p style="text-align: center;">ON</p> 	
		AC output OFF: AC output will be off when connecting to the mains supply in any mode.		AC output ON: AC output will be on when connecting to the mains supply in any mode.	

14

Battery Communication Settings

0-Lead acid battery(default)

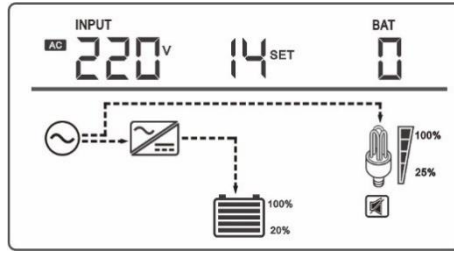

1-Voltronic Communication

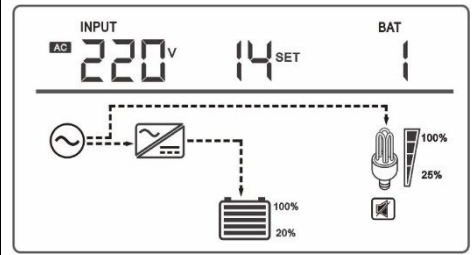

2-Pylontech Communication

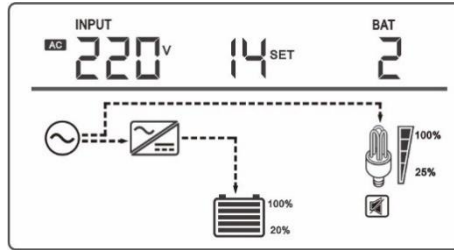

3-Growatt Communication

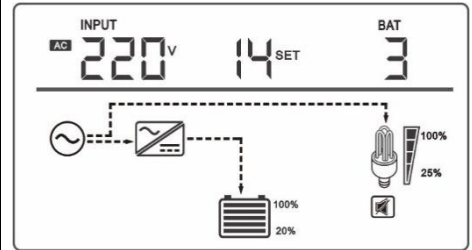

4-SNAT Communication

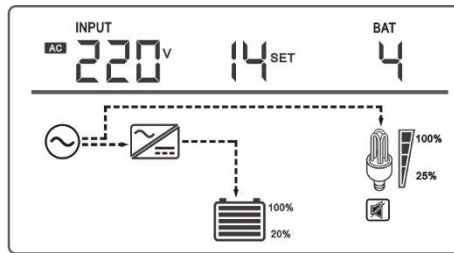

Lead acid battery by default, optional lithium battery after entering

When the lithium battery protocol is selected and communicated, the battery displays the percentage of capacity (the lead-acid battery displays the battery voltage value unchanged).

When receiving the lithium battery cell or total voltage level 1 overvoltage alarm, reduce the charging current to xx %, and reduce the charging voltage value.

When receiving the lithium battery cell or total voltage one undervoltage alarm, the inverter turns off the AC output and reports E06.

***When the inverter is not equipped with lithium battery communication port, the battery defaults to lead-acid 0 mode**

5 Equipment wiring diagram guide

(1) 12VDC series battery wiring graphical representation

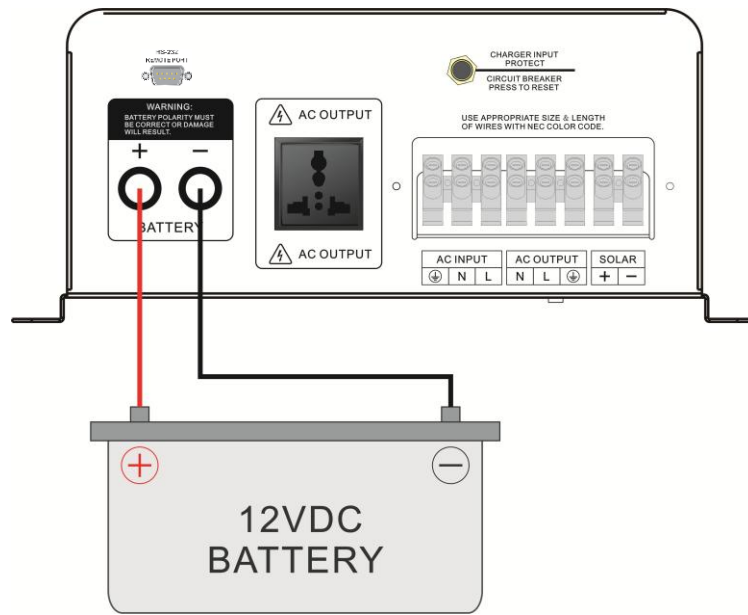

(2) 24VDC series battery wiring graphical representation

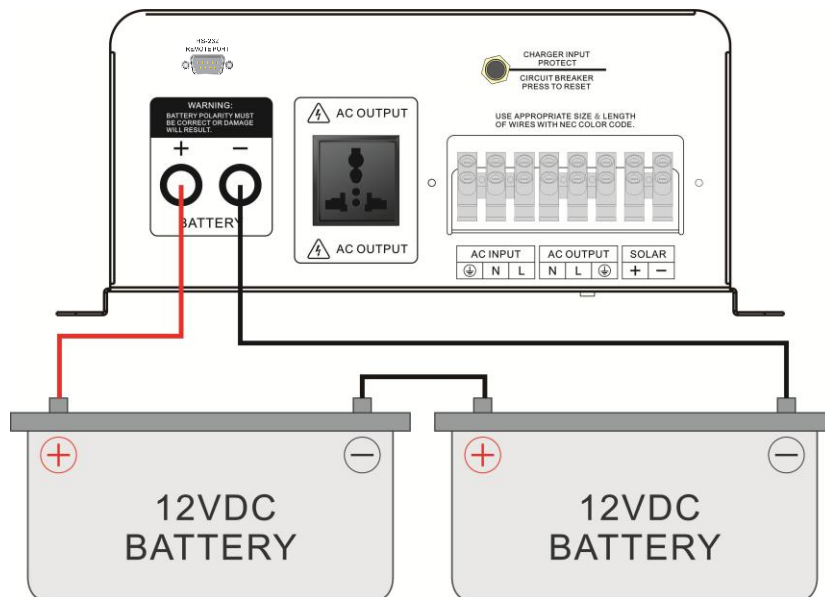

(3) Input/Output wiring diagram

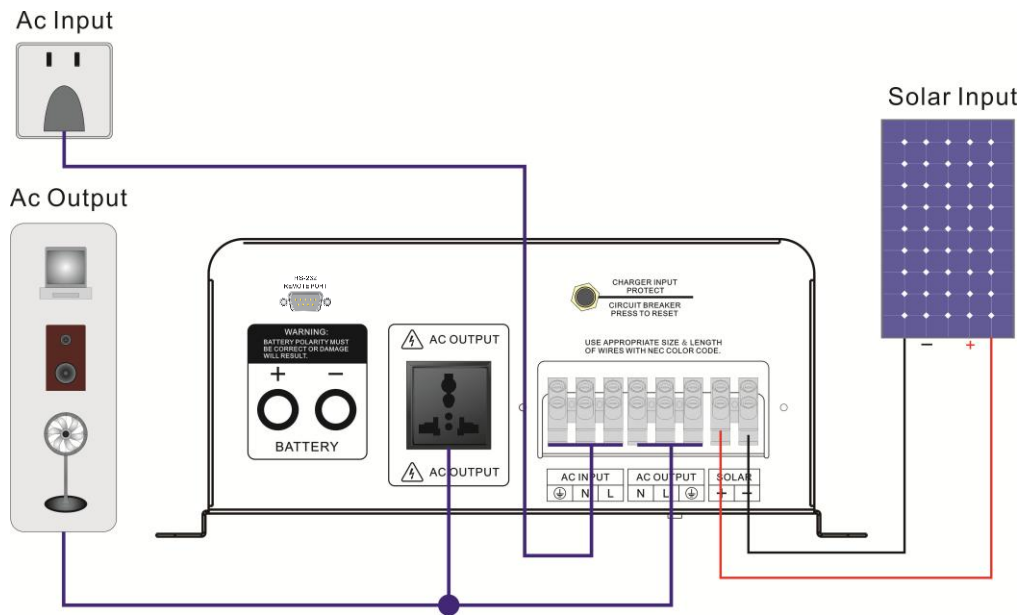

(4) Direction for using of wire diameter

Direction for using of battery, AC input/output wire diameter: (Compute depends on 1mm² copper core with 4-5A current)

$$\text{Battery wire diameter} = \frac{\text{Rated power(W)}}{\text{Rated battery(V)} \times 5\text{A/mm}^2}$$

$$\text{AC wire diameter} = \frac{\text{Rated power(W)}}{\text{Rated AC voltage(V)} \times 5\text{A/mm}^2}$$

For example: Wire diameter of 5000W/48Vdc/220Vac as below.

$$\text{Battery wire diameter} = \frac{5000\text{W}}{48\text{V} \times 5\text{A/mm}^2} \approx 20(\text{mm}^2)$$

$$\text{AC wire diameter} = \frac{5000\text{W}}{220\text{V} \times 5\text{A/mm}^2} \approx 6(\text{mm}^2)$$

6 Care and Maintenance

(1) This series products only need rarely care, battery only need keeping charging so that can get expected lifetime.

(2) If the equipment will not be used for long-term, we suggest it should be charged 1 time every 4~6 month. Usually, the battery can be used for 3~5 years, if it has some problem, then the battery should be changed as soon as possible. When changing battery, it must be operated by professional and obey battery supplier indicate.

(3) Before changing the battery, it must be closed equipment and break away from the grid, close the battery switch. Take off the metal objects such as rings.

(4) Connect the battery line, tiny spark in joint belongs to the normal phenomenon, and will not cause harm to the personal safety and equipment. Never connect the battery positive and negative into short or the reverse.

7 Error code and solution

Error code	Faulty	Solution
E01	Overcurrent of MOSFETS board	Kindly contact sales if still having this issue after restarting
E02	Output short circuit	Check whether it's overloaded seriously or short circuit inside appliances loaded
E03	Appliance Overloaded	Check whether it's overloaded, and remove some loads not important
E04	Inner Over-temperature	Check whether fan is working well or the air dust for cooling be blocked
E05	Overvoltage of battery	Check whether battery connection and configuration correct
E06	Battery's voltage is lower than shutdown voltage	Make sure battery be fully charged, or replace new battery
E07	Reverse connected cables between transformer with heatsink on power board	Fix the two cables after they are interchanged
E08	Start Protection when low output voltage	Kindly contact sales if still having this issue after restarting
E09	Reserved	-----
E10	Undervoltage of battery	Check the system voltage of inverter and use same data for the battery pack.

8 Judgment and treatment for simple faults

Warning: High voltage inside the device! Do not open it by yourself, or try to do maintenance, so as not to be in danger!

Fault	Possible causes	solution
Time degradation of Machine with loads	Battery undercharge	Make sure battery be full of charging normally
	Machine connect load overcharge	Move away non-key loads
	Battery burn-in and can't charge enough power	Please contact with CSR and get battery need changing module
The machine can't be started	The grid input line or battery input line is in bad connect	Check and reconnection
Starting up alarm	Low battery	Make sure battery be full of charge normally
	Overload	Move away non-key loads
Buzzer for 2s, pause 1s	Internal over-temperature	Check fan and hear dissipation whether be blocked
Fan sometimes fast, sometimes slow	Internal temperature above 45°C fan fast, below 42°C fan slow	Normal

When you contact with engineers, please provide the following information: machine model/problem date/complete description of the problem (including indicator status, battery specification, all of the connection etc).

9 Technology Parameter

Type: NKM-		1000E	
Rated power		1000W	
Battery	Rated voltage	12V	24V
	Charge current (can be set)	0-15A	
Input	Voltage range	73-138VAC/145-275VAC	
	Frequency	45-65Hz	
Output	Voltage range (can be set)	100/110/120(VAC)	
		200/210/220/230/240(VAC)	
	Frequency	50/60Hz±1% (Inverter mode)	
	Output wave	Pure sine wave	
	Switching time	< 10ms(typical load)	
	Efficiency	> 85% (80% Resistance load)	
	Overload	110-120%/60s;120-130%/10s;130-150%/2s;>150%/500ms	
Protection	Battery overvoltage/low voltage, overload, short circuit protection, overtemperature protection, etc.		
Solar Controller	MPPT Voltage Range	18V~100V	34V~100V
	Max. PV Input Power	570W	1130W
	Rated charge current	40A(Max)	
	MPPT efficiency	≥99%	
Operating ambient temperature		0-40℃	
Storage ambient temperature		-15 - +50℃	
Operating/Storage ambient		0-90℃ No condensation	
Machine Size: L*W*H (mm)		331*307*130	
Package Size: L*W*H (mm)		390*350*200	

Note: Our company has the right of changing this user manual without any information

